

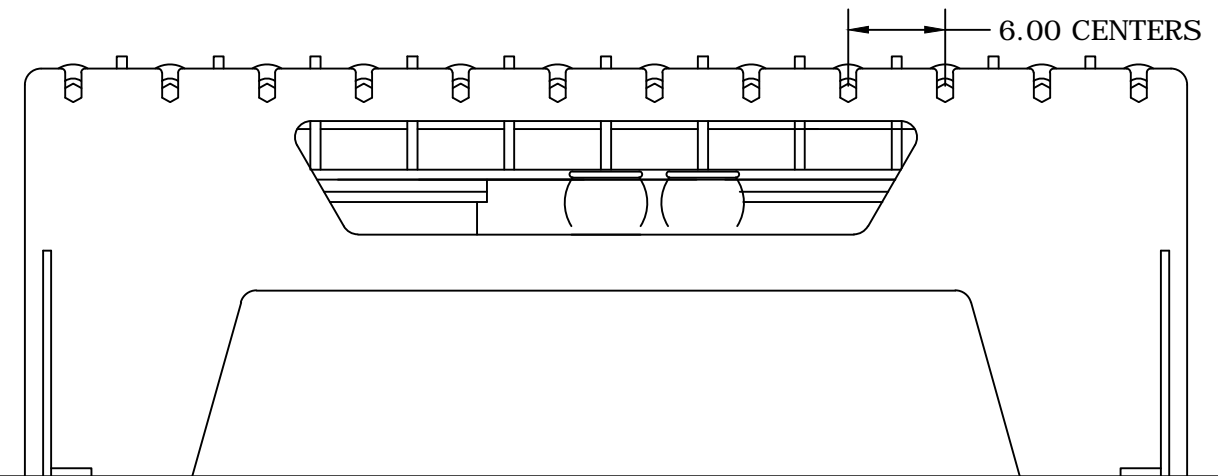

- NOTES:
 1 - (8) Ø3.5", .300 WALL ROLLERS
 2 - WHEN AIRBAGS ARE DEFLATED
 T.O.R. WILL BE 26"

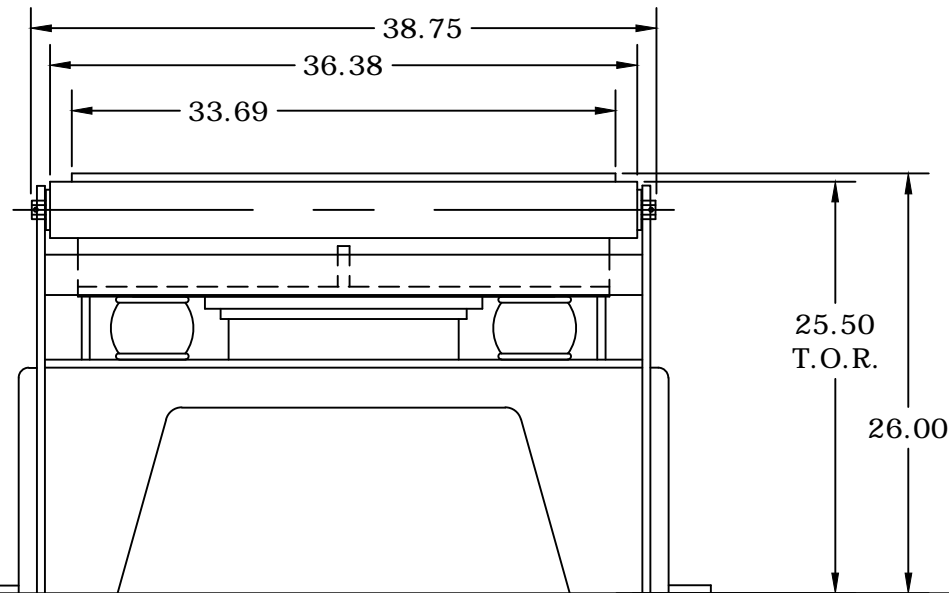
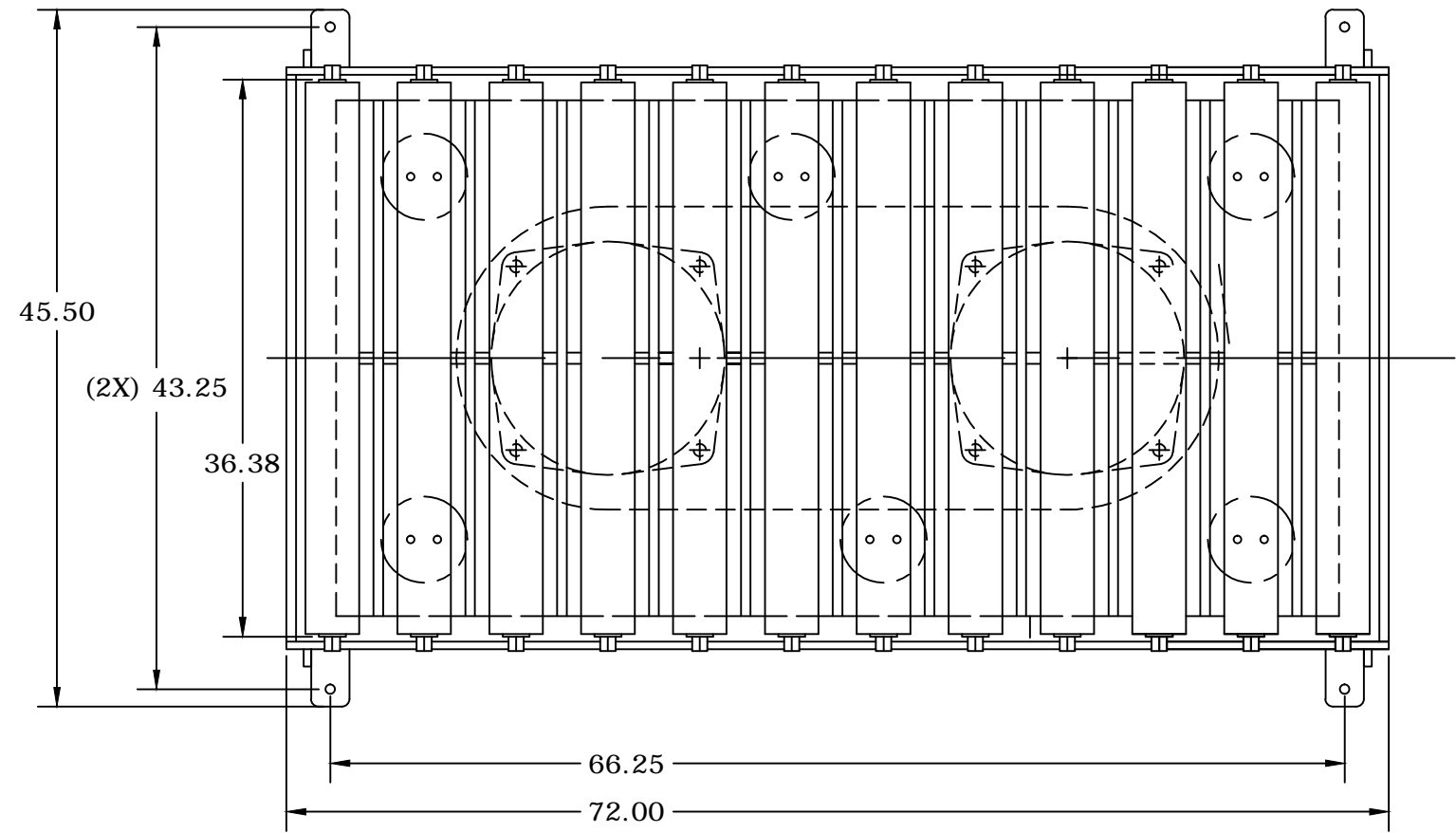

CUSTOMER APPROVAL
 SIGNATURE: _____
 DATE: _____

<p align="center">CONFIDENTIAL</p> <p>THIS DOCUMENT, INCLUDING ALL INFORMATION HEREIN, IS THE EXCLUSIVE AND CONFIDENTIAL PROPERTY OF PALMER MANUFACTURING. THEREFORE THIS DOCUMENT IS NOT TO BE COPIED, REPRODUCED, OR DELIVERED TO OTHERS WITHOUT THE EXPRESS WRITTEN PERMISSION OF PALMER.</p>			18 BECHTLE AVENUE SPRINGFIELD, OHIO 45504 U.S.A. (937) 323-6339 OR 1-800-457-5456
	SCALE: NONE	APPROVED BY: _____	DRAWN BY: SLW/CLA
	DATE: 12-2-10	TITLE: V3000-I-CLB COMPACTION TABLE	
	PREVIOUS DWG. #: N/A	DWG. #: V10152	REV: A
NOTE: DUALTECH A TABLE SHOWN IN RAISED POSITION			PG. #: 1 OF 14